

فورمولا إثارة
**FORMULA
ETHARA**

FORMULA ETHARA CAR MAKERS MANUAL

#EtharaAtHome

EDITION



**YAS MARINA
CIRCUIT**
حلبة فرسي ياس

**YAS
IN SCHOOLS**
ياس في المدارس

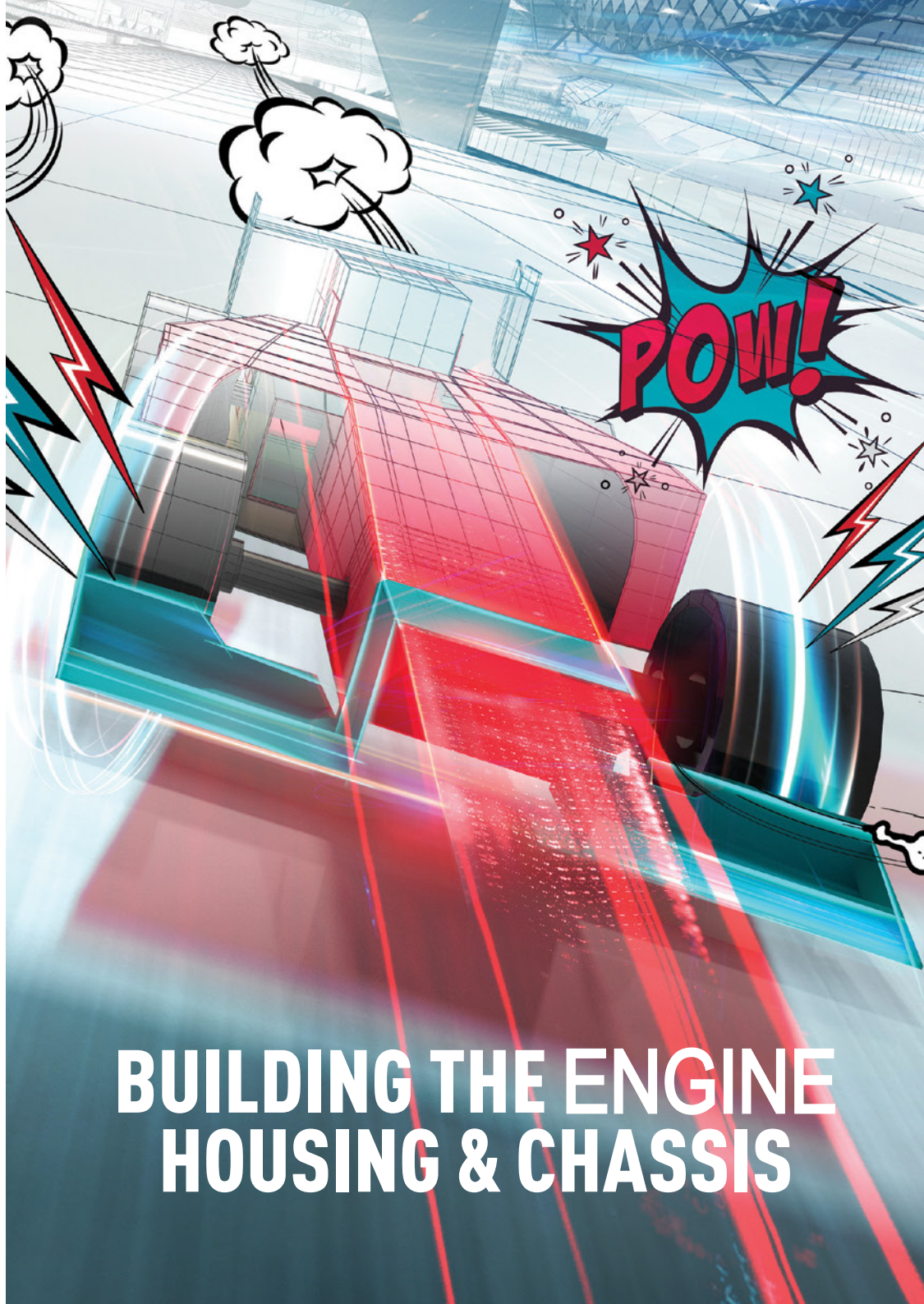

BUILDING THE ENGINE HOUSING & CHASSIS



Think about.... IMPORTANT, build your chassis as accurately as possible. To do this, you should:

This instruction guide for #EtharaAtHome is based on the instructions for the standard Formula Ethara car. Small changes to note for #ETHaraAtHome are in RED text

- Follow all instructions carefully.
- Make sure all edges are in line..
- Take your time, work slowly.
- Pay attention to detail

Engine Housing

We will begin by making the canister housing.

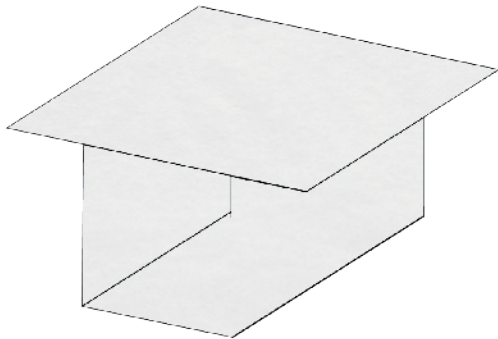

Your template will look like the image below.

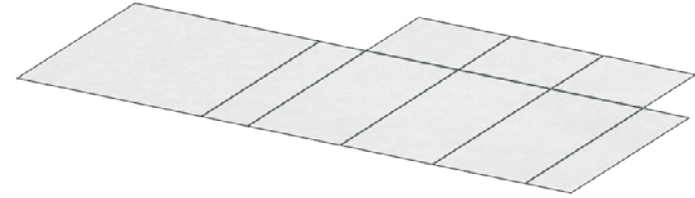

Begin by making inward folds as shown below.

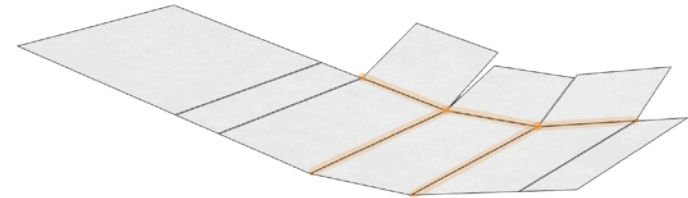

Now make outwards folds as shown below.

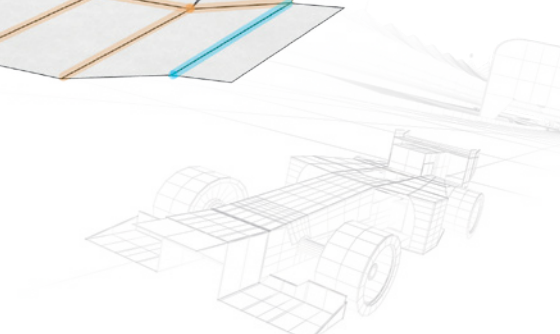
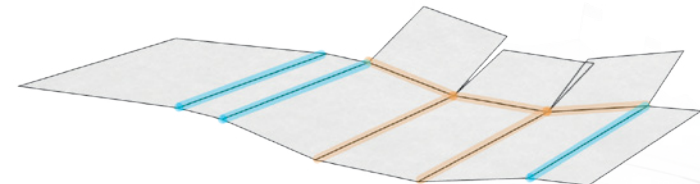



Before starting the gluing process, do a practice run. Follow the instructions to complete the engine housing without glue. Once you have mastered it, go back and do it again, but this time with glue.

Step 1:

Fold flap 2 upwards.

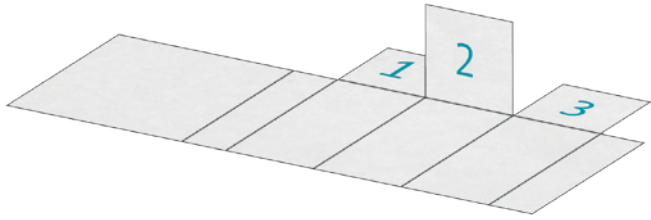

Step 2:

Apply glue to flap 1.

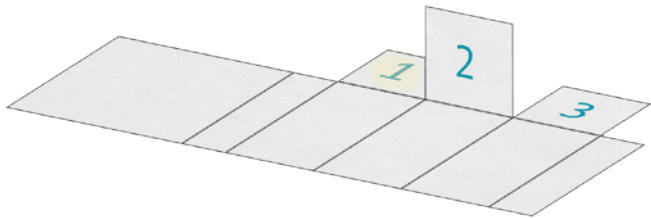

Step 3:

Glue 1 and 2 together so that the back of 2 is on 1.

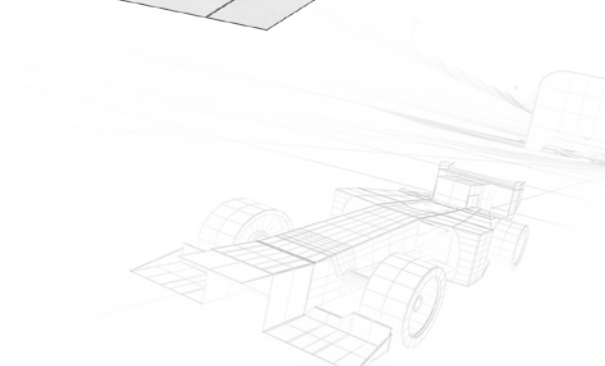
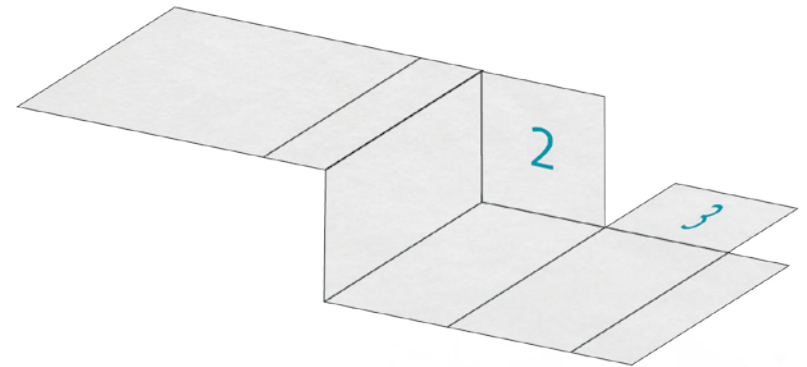
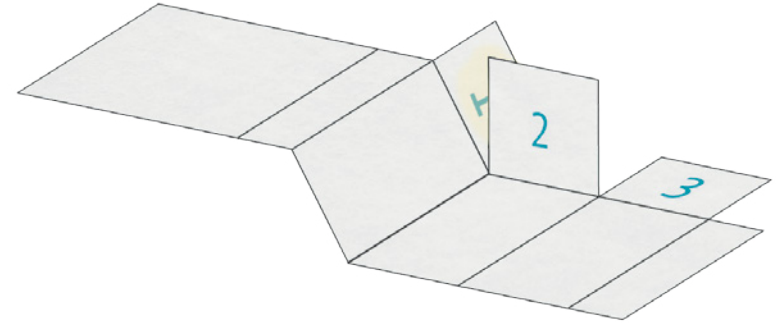

Step 4:

Fold over the right side

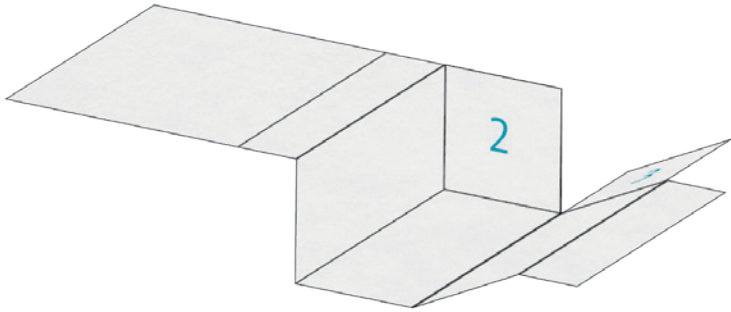

Step 5:

Apply glue to the front of 2. Stick the back of 3 to this.

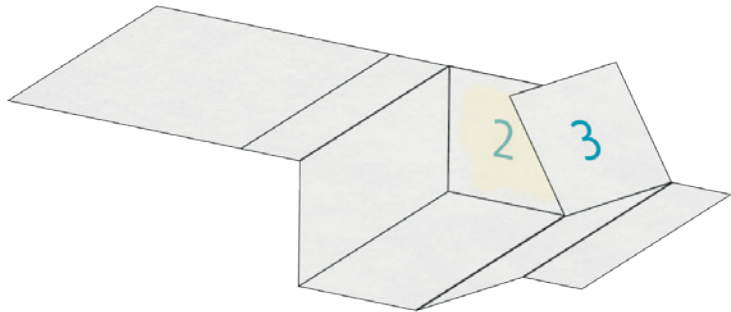

Step 6:

Stick 2 and 3 together. Fold right flap out.

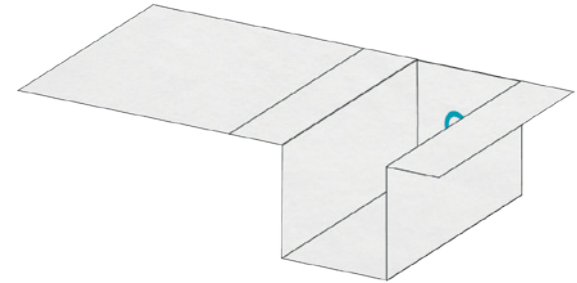

Step 7:

Apply glue to the side panels.

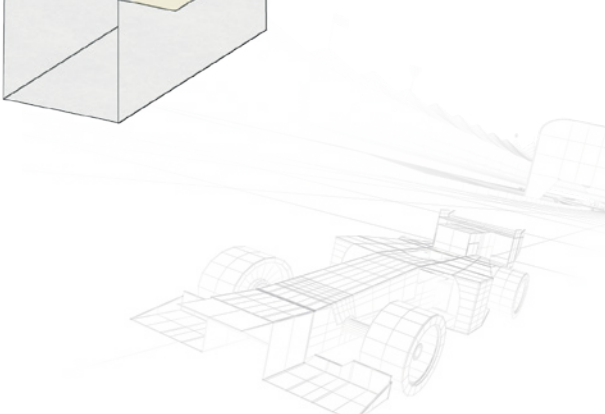
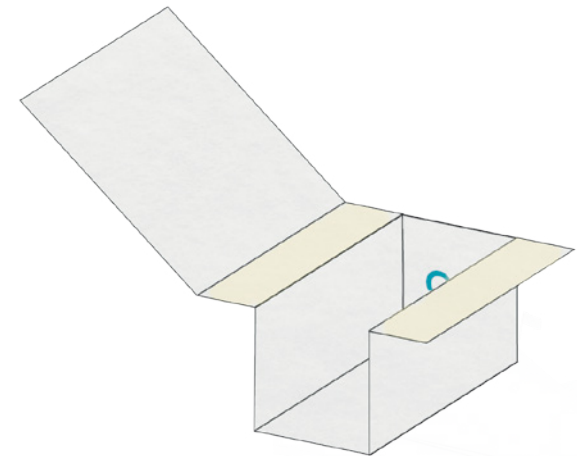

Step 8:

Fold the last flap over.

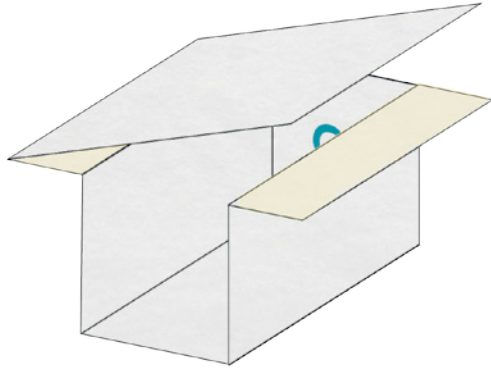

Step 9:

Glue the top flap onto the side panels. Make sure all the edges are lined up.

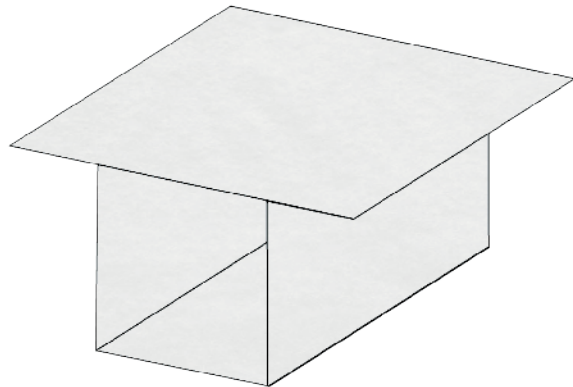

The canister housing is now complete.

Building the chassis

Now that the engine housing is built, we can make the chassis of the car. Below is the template that will be used. Position your template as shown below.

The picture below looks a little different to your #EtharaAtHome Chassis Template. Don't worry, the differences are easy to handle and shown in the later steps...

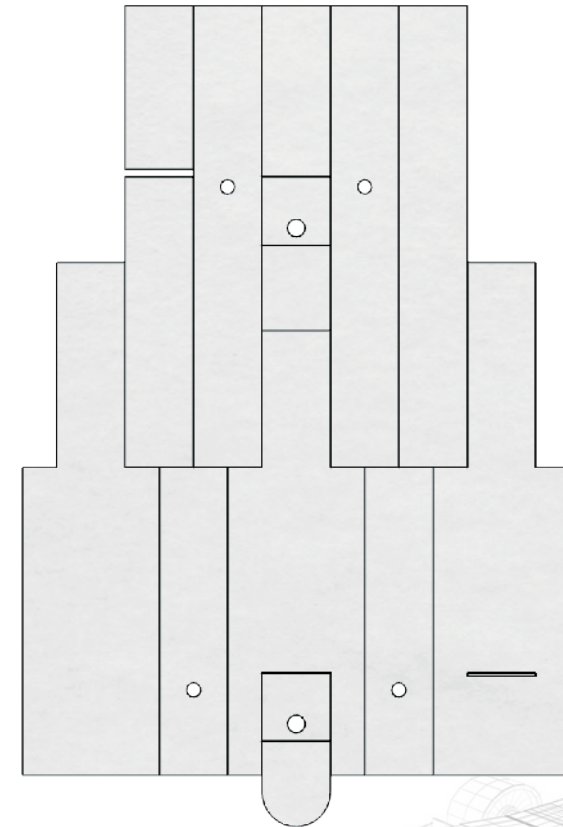

Step 1:

Fold the highlighted creases inward.

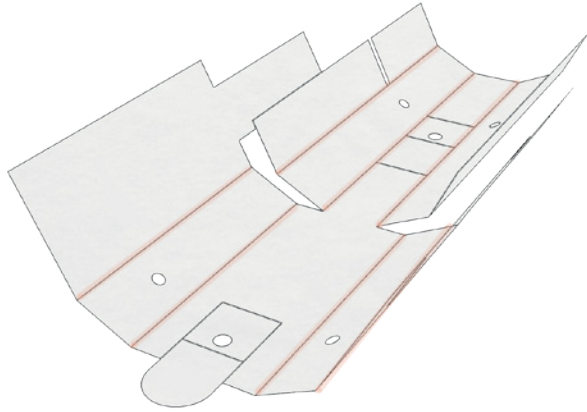

Step 2:

For #EtharaAtHome, we can ignore this step

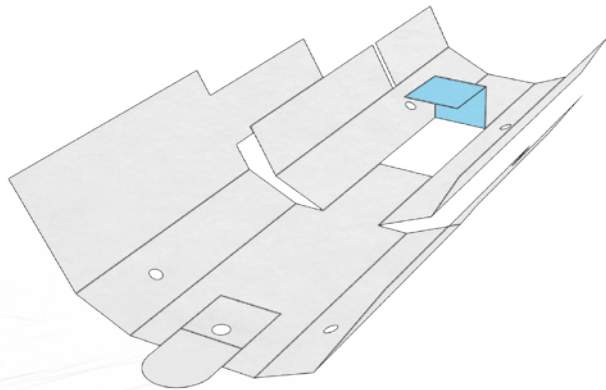

Step 3: **For #EtharaAtHome, we can ignore this step**

Now fold flap labelled 1, which is pink, upwards as shown below.

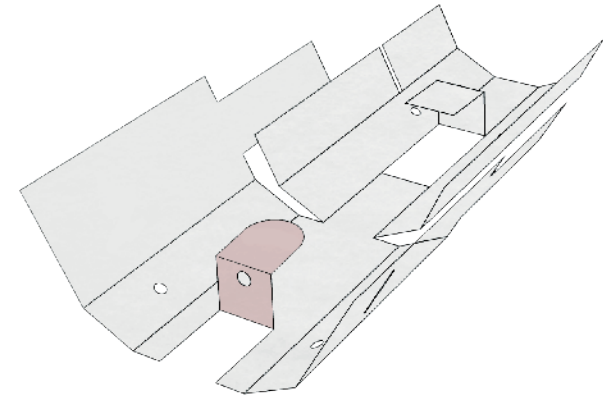

Step 4:

Now that the folds are done turn the template upside down. The back should be facing up.



Note: there should be no writing on this side.

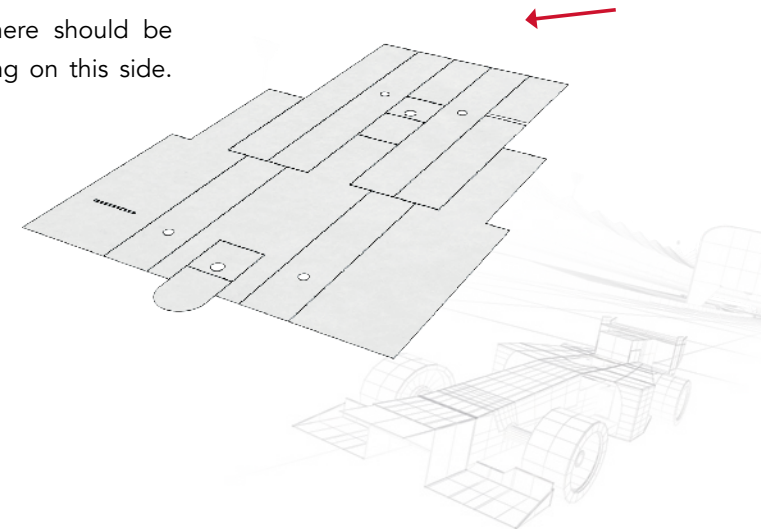

Step 5:

Line up the canister housing with the chassis template as shown below.
Note: The open end should be in line with the edge of the chassis template.

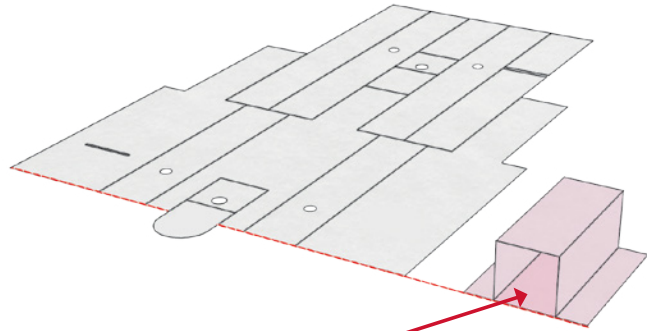

Open end facing this way

Step 6:

Apply glue to the areas shown.

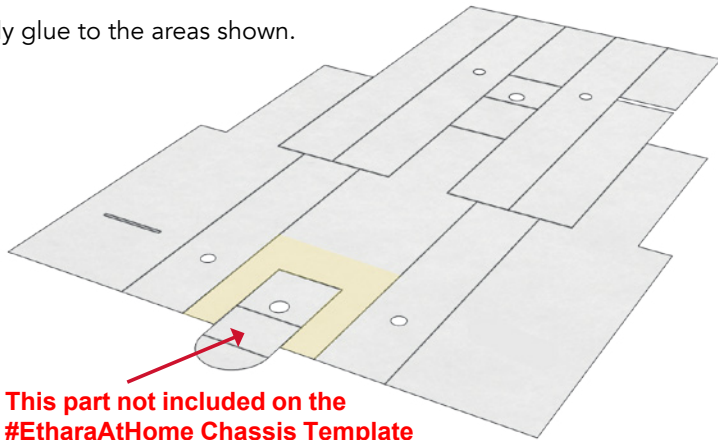

This part not included on the #EtharaAtHome Chassis Template

Step 7:

Stick the canister housing to the chassis template. Be sure to carefully align the edges of the canister housing to the matching edges of the chassis template.

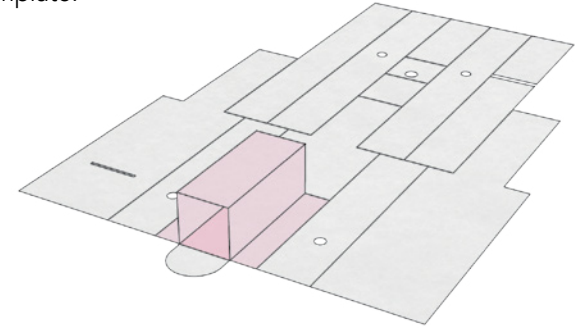

Step 8:

Once the glue has dried, staple the two parts together as shown below.

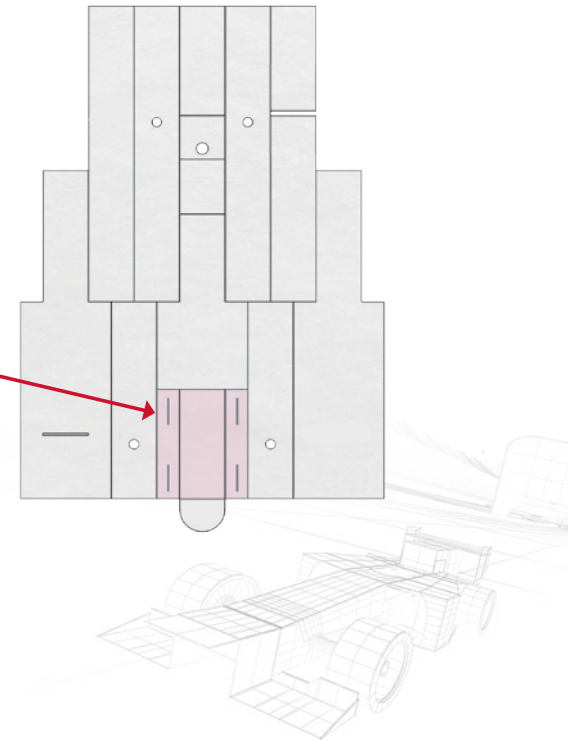

Staples X 4

Step 9: **For #EtharaAtHome, we can ignore this step**

Lift up the flap shown in the picture. Make sure it is straight up.

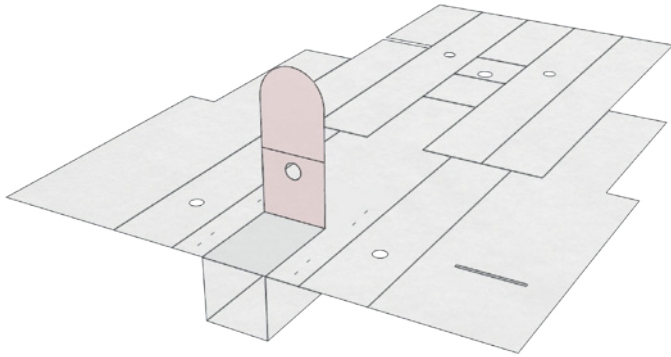

Step 10: **For #EtharaAtHome, we can ignore this step**

Lift up the right-hand side panel, so it is vertical.

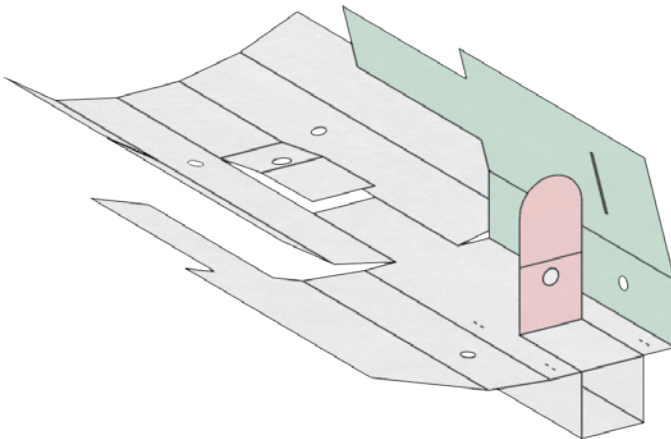

Step 11: **For #EtharaAtHome, we can ignore this step**

Fold over the top half, inserting the round flat into the slit.

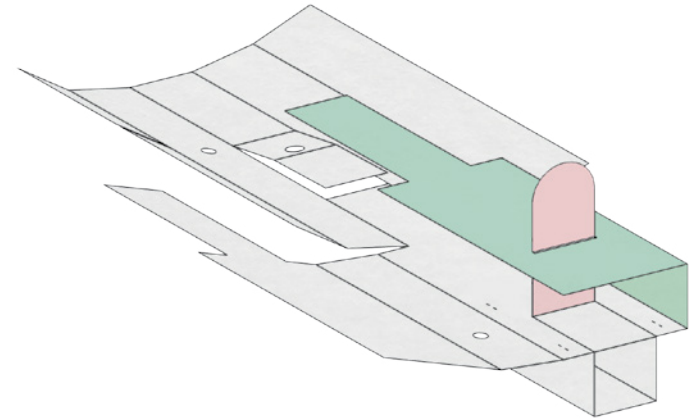

Step 12:

Simply fold over the right side flap as shown in green colour below. The tab coloured pink below is not part of the #EtharaAtHome Chassis Template

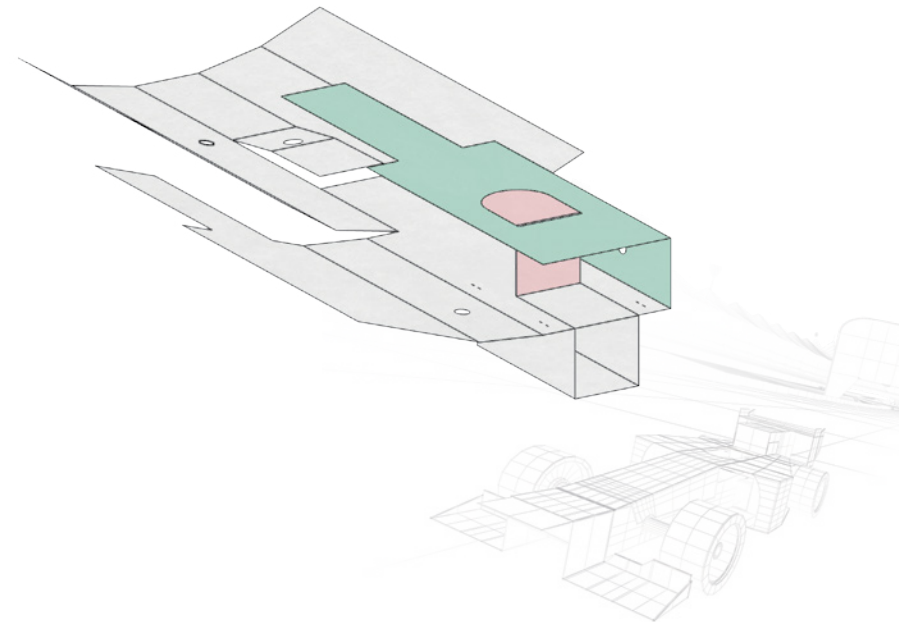

Step 13:

Turn the chassis around by 180 degrees as shown below. This is so we can work on the other side.

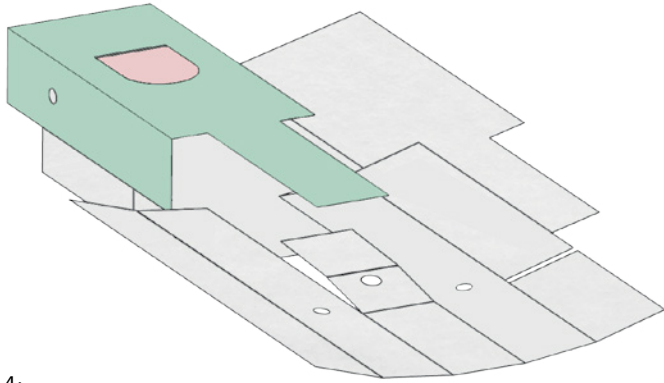

Step 14:

Fold up the flap on the right side, so it is vertical.

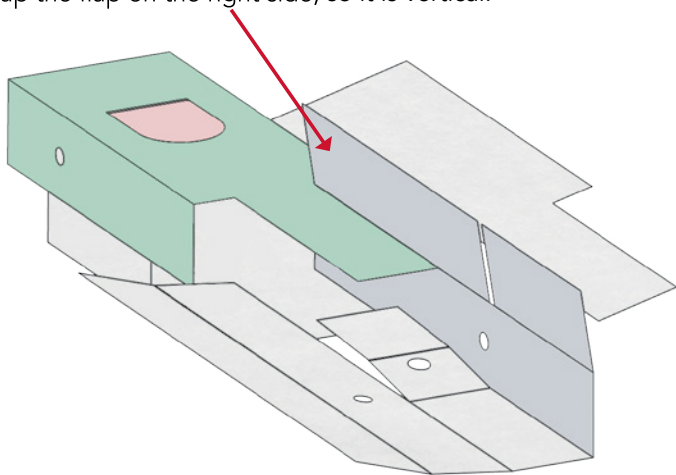

Step 15:

Apply glue as shown by yellow colouring

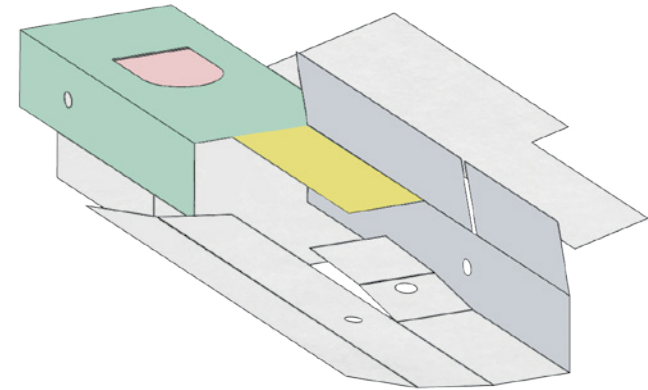

Step 16:

Glue the perpendicular flap down as shown. Press down firmly. Make sure to keep everything straight and lined up.

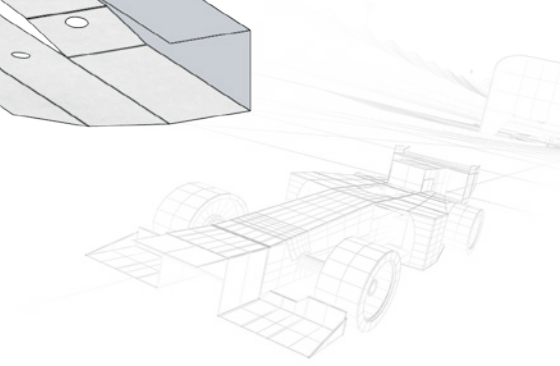
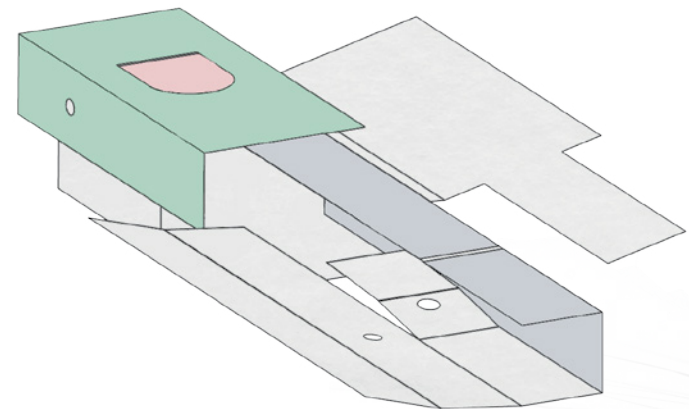

Step 17: **For #EtharaAtHome, we can ignore this step**

Slot the tab through the slit, so it is vertical.

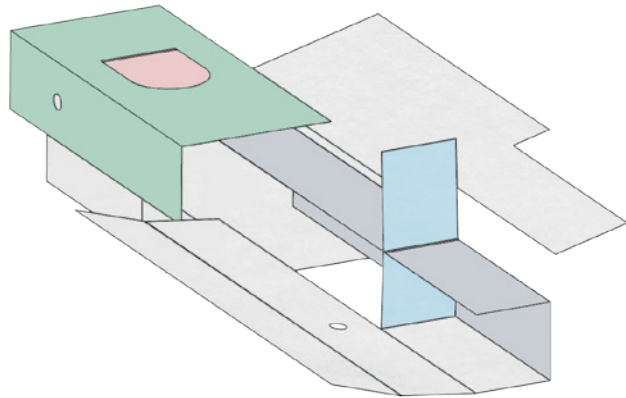

Step 18: **For #EtharaAtHome, we can ignore this step**

Apply glue to the reverse side of the top half of the tab. Glue it down.

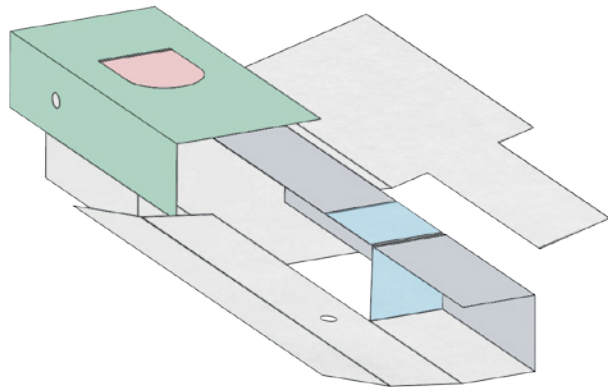

Step 19:

Lift up the flap on the right side, so it is vertical.

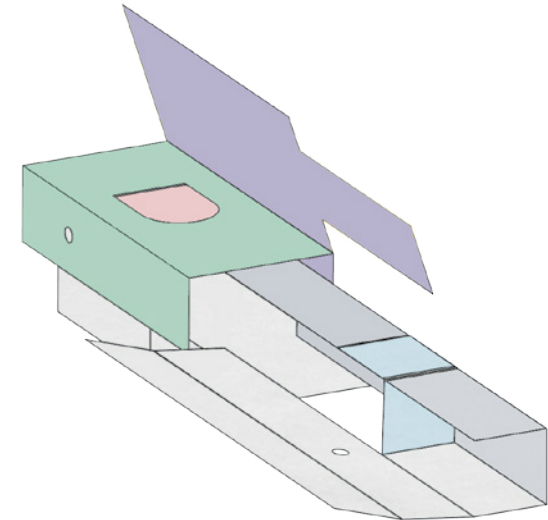

Step 20:

Apply glue to the inside of the flap

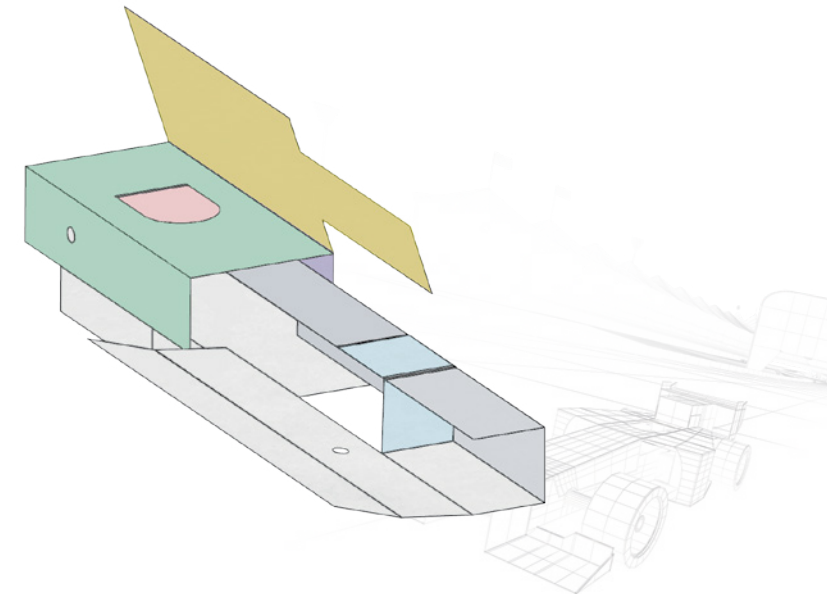

Step 21:

Glue the flap down as shown. Press down firmly.

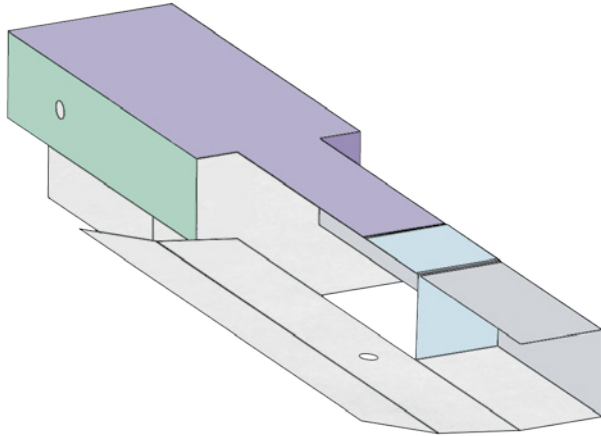

Step 22:

Lift up the left-hand panel, so it is vertical.

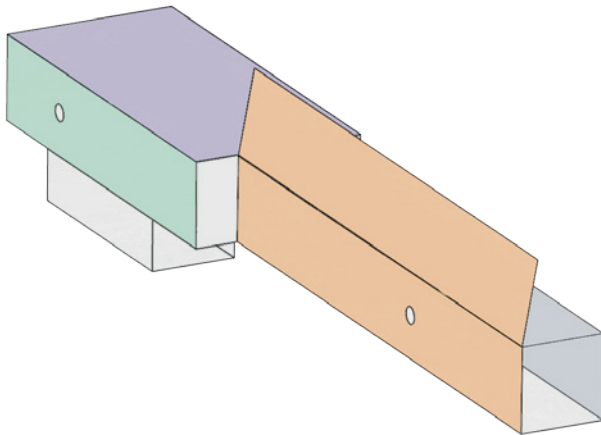

Step 23:

Apply glue to the final panel and press it down.

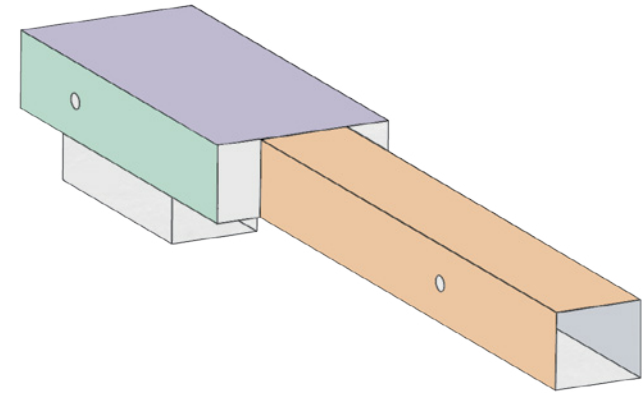

Step 24:

Check that your chassis looks like the diagram below.

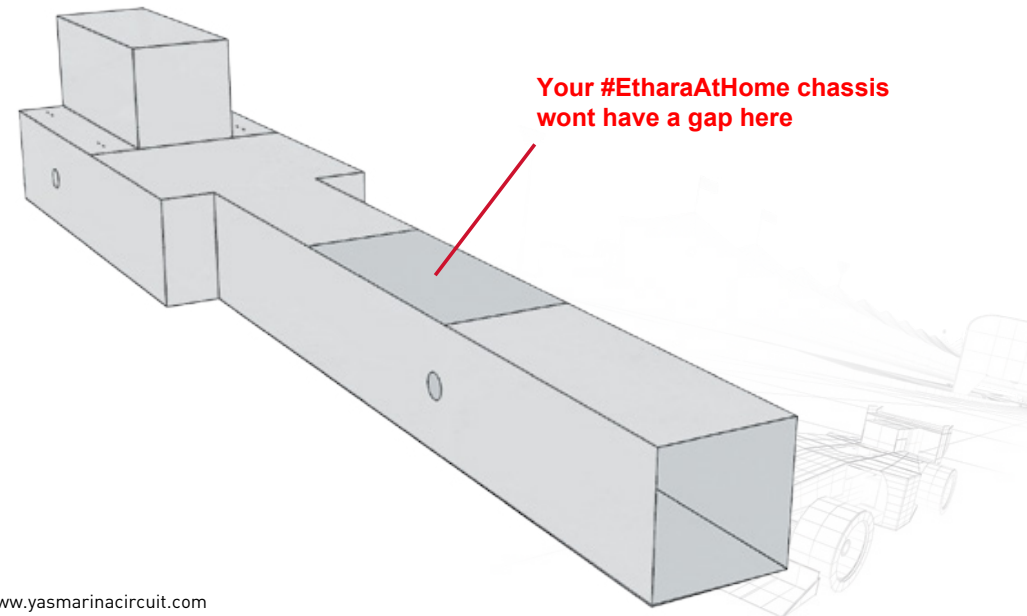

FOR MORE INFORMATION

Call 800 YAS (927) | Email yasinschools@ymc.ae | Visit www.yasmarinacircuit.com



CAR BODY ASSEMBLY

Car body assembly

Once you print the outer case, you can attach it to the chassis.

Step 1:

Create the folds, as shown below.

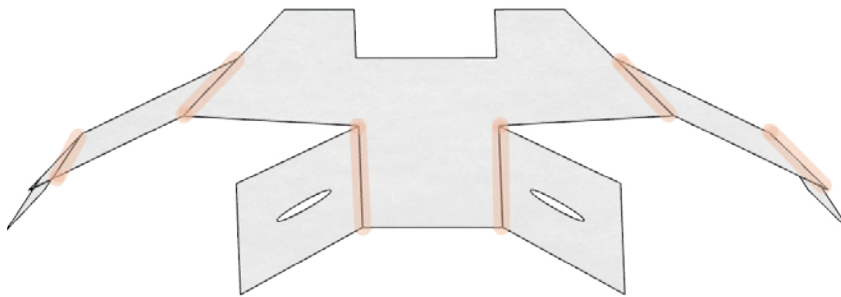
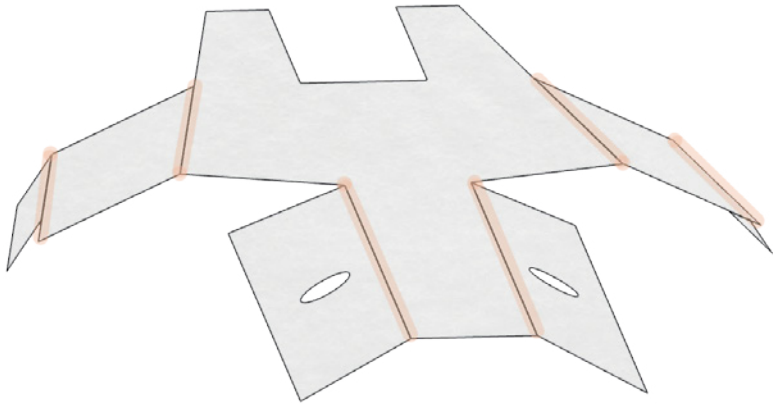

Step 2:

Align the base to the top of the outer body.

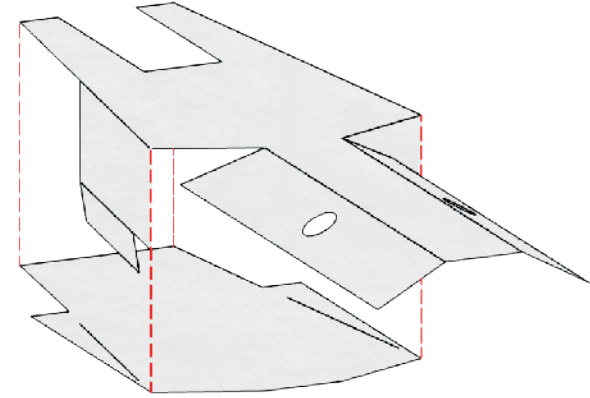

Step 3:

Insert the tabs through the slits.

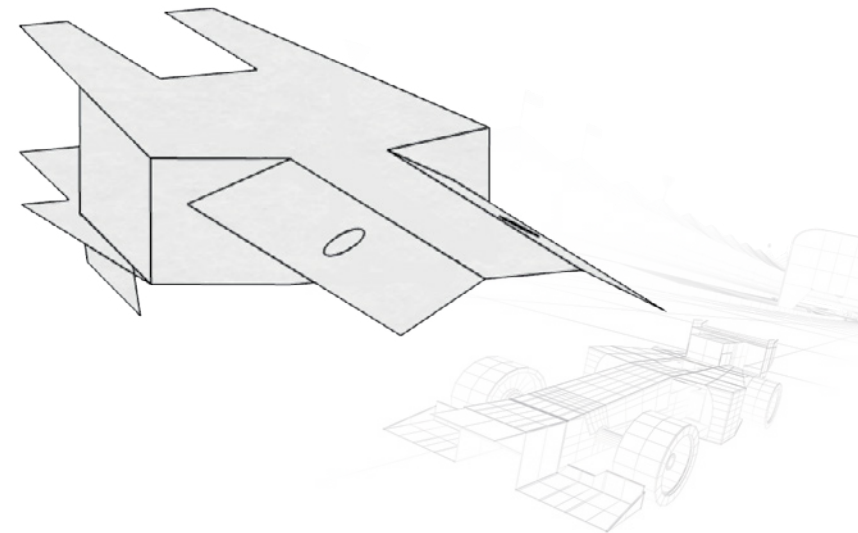

Step 4:

Apply glue to the inner sides of the tabs.

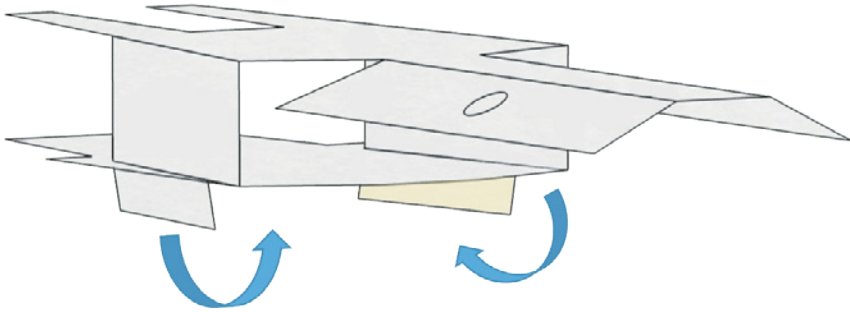

Step 5:

Press tabs down firmly.

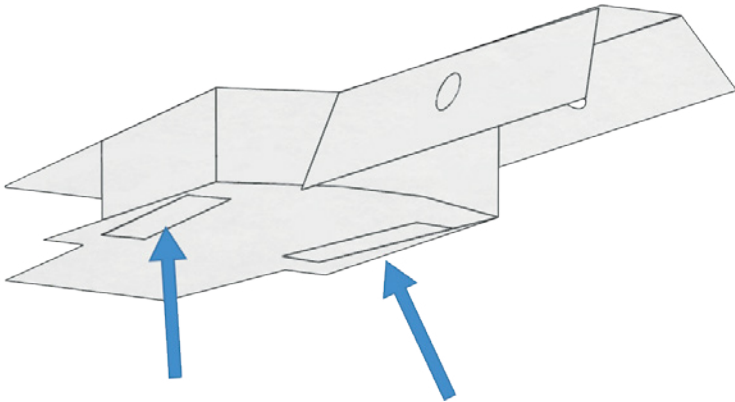

Step 6:

Remove the wheels. Put glue on the parts of the chassis shown below in yellow.

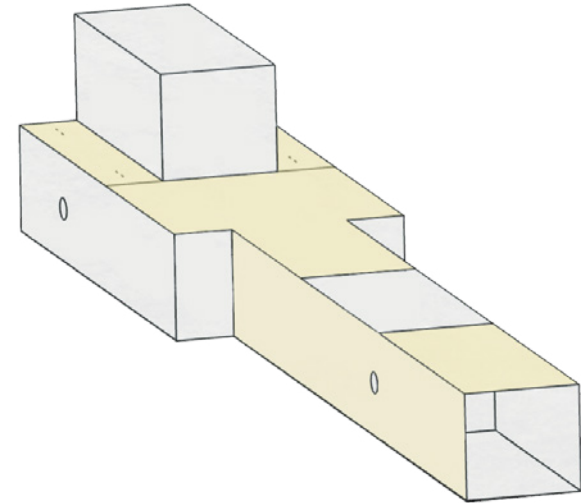

Step 7:

Slide the car body onto the chassis.

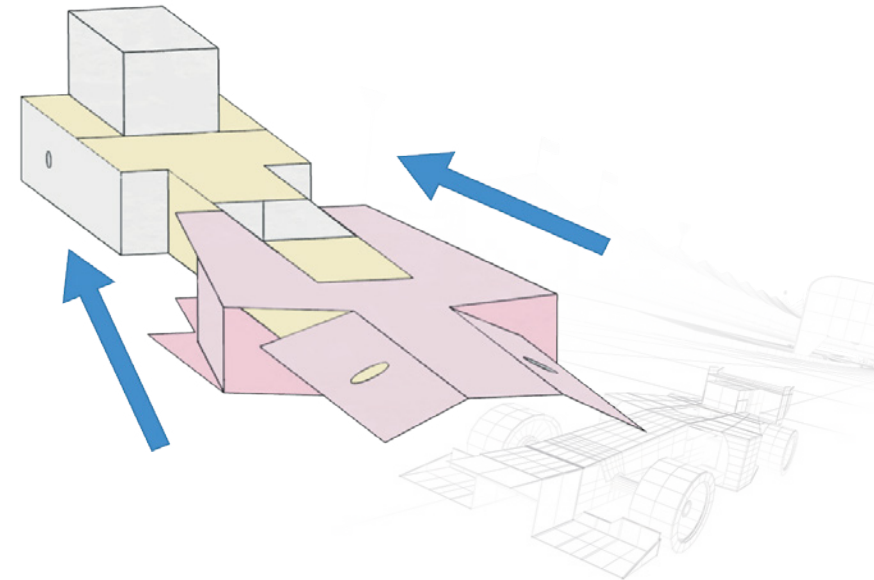

Step 8:

Press firmly where you put the glue.

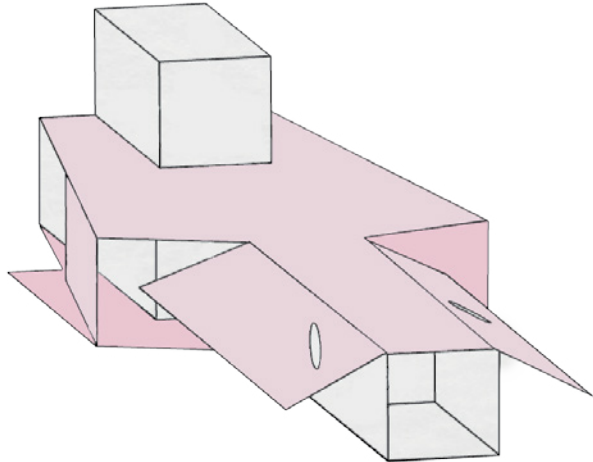

Step 9:

Press down the side panels at the front.

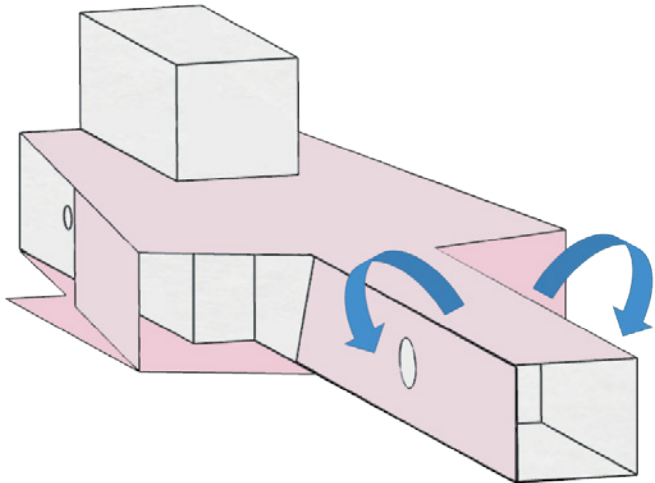

Step 10:

Attach the front and back wings.

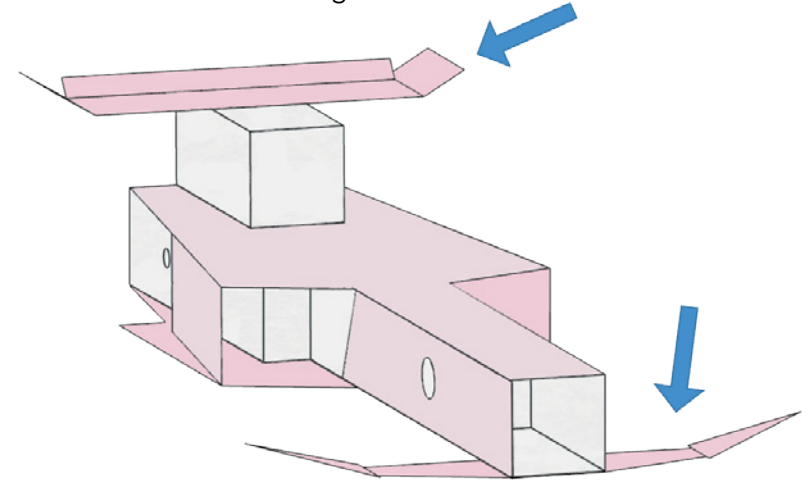

Step 11:

Your done! Now its time to add wheels'

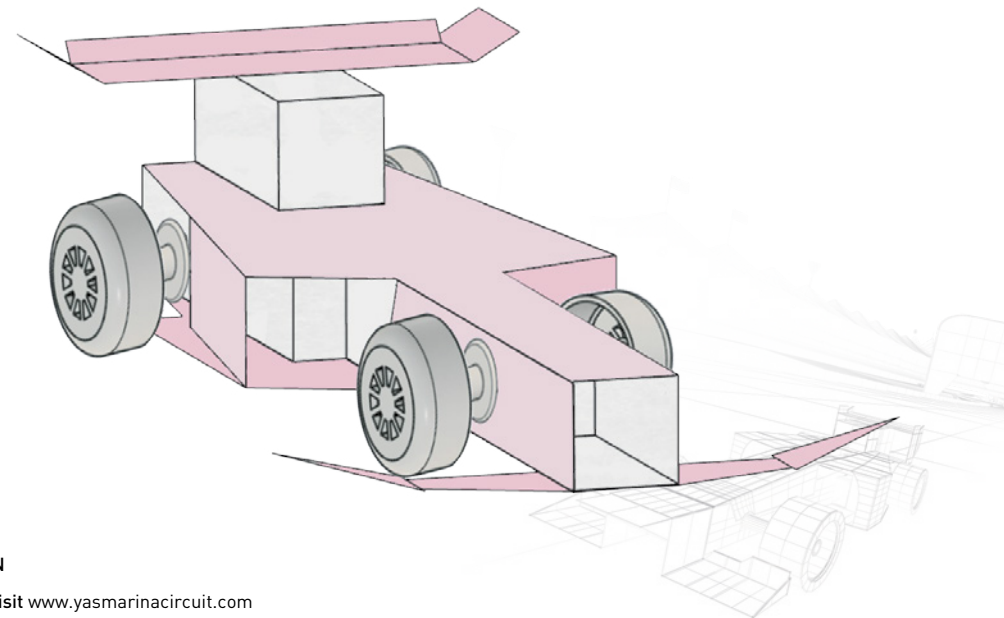

FOR MORE INFORMATION

Call 800 YAS (927) | Email yasinschools@dymc.ae | Visit www.yasmarinacircuit.com