

1.2 The Main Components of Computer Systems

- Describe the central processing unit including its role
- Describe internal memory, i.e. ROM and RAM and the differences between them
- Define input and output devices and describe the difference between them
- Define secondary/backing storage

1.2 The Main Components of Computer Systems

Describe the central processing unit including its role

- The CPU is the **'brain'** of the computer.
- It is where all the searching, sorting, **calculating** and **decision making takes** place.
- The speed of the CPU is measured in **Gigahertz** (GHz).
- A 1 GHz CPU can carry out 1 billion instructions per second!
- Intel and AMD are the most popular CPU brands.

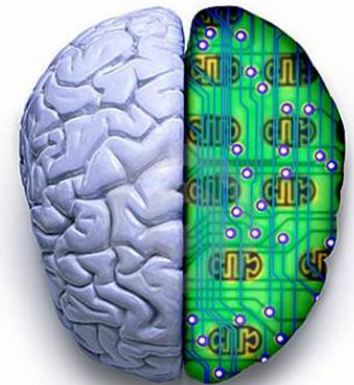

ICT IGCSE Theory – Revision Presentation

1.2 The Main Components of Computer Systems

Main Memory

Applications are installed in the **Secondary Storage (Hard drive)**.



Temporary data from Applications in use are held in the **Main Memory**.



The CPU will **first check the Cache** for the **required piece of the data so that it can be processed**.



If the data is not in the cache then the **CPU will check the RAM and transfer data to the CPU**.



The Cache will then **transfer the next piece of data from the RAM into Cache**.



The CPU will again **check the Cache** for the next piece of data. **This time the CPU will be able to get the data from the Cache Memory.**

ICT IGCSE Theory – Revision Presentation

1.2 The Main Components of Computer Systems

Main Memory

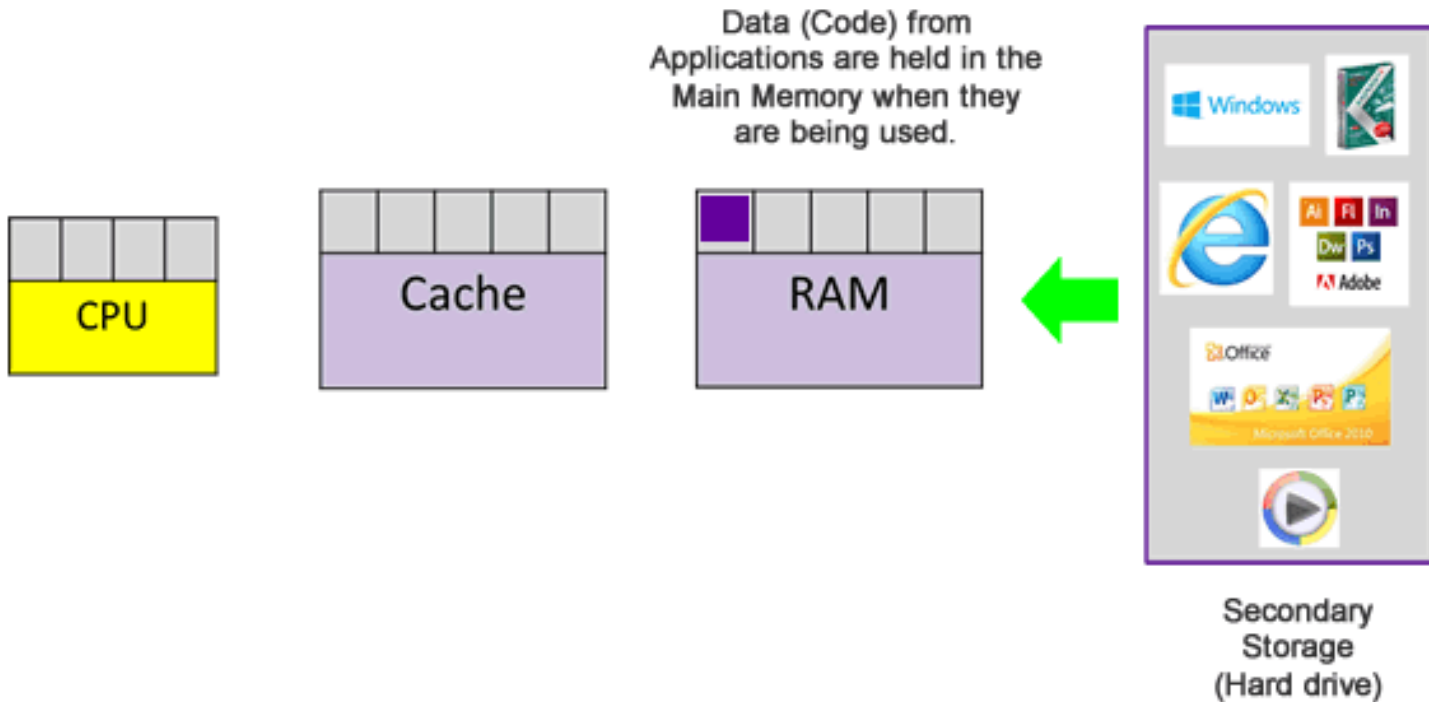

1.2 The Main Components of Computer Systems

Cache

- **Cache is the fastest type of Memory.**
- It is located between the **processor** and the **RAM**.
- Cache collects **data from the RAM**.
- Holds onto **commonly used data**.
- The Cache will **automatically transfer the next set of data from the RAM in to the Cache** so that it can be **processed by the CPU**.



1.2 The Main Components of Computer Systems

RAM (Random Access Memory)

- **RAM** stands for **Random Access Memory**
- **RAM** is the part of the computer that temporarily stores the instructions that the computer is running whilst the data is being processed by the **CPU**.
- **RAM** is volatile which means that when the computer is **turned off all data is lost**



1.2 The Main Components of Computer Systems

ROM (Read Only Memory)

- **ROM** stands for **Read Only Memory**
- ROM is a built in memory that **can not be changed** (Read Only).
- ROM normally holds the '**boot up**' instructions to start the computer – without it the computer wouldn't know what to do when on button is switched on (**e.g. the operating system will not start**).
- ROM is **non-volatile** memory which means that memory is **not lost when computer is turned off**.

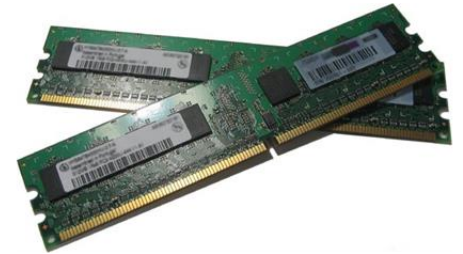

ICT IGCSE Theory – Revision Presentation

1.2 The Main Components of Computer Systems

Input and Output devices

Devices need to be connected to a computer to allow data to be inputted and outputted.

The general name for these extra devices is 'peripheral devices'. They are usually categorised into **input** devices, **output** devices and **storage** devices.

Input	Output	Storage
		

An **input device** is a device that can **pass data into the computer**

Devices that **take data from the computer** are known as **output devices**.

ICT IGCSE Theory – Revision Presentation

1.2 The Main Components of Computer Systems

Define secondary/backing storage

Backing storage is also known as **secondary storage**

Backing storage is non-volatile which means that data is not lost when computer is turned off.

Backing storage is used to store data for a long time (data can be read from and written to)

Users tend to **make copies of original files** on backing storage.

